

**Upgrade  
of the L1 Muon Trigger  
for CMS  
Lev Uvarov**



Mar 28, 2013

---



# Motivation and Requirements

Current design for: 25 ns,  $L \leq 1 \times 10^{34}$ , PU ~ 25

After LS1	# bunches	Luminosity (L) Hz/cm <sup>2</sup>	Pile-up (PU)
25 ns	2760	$9.2 \times 10^{33}$	21
25 ns low emit	2320	$1.6 \times 10^{34}$	43
50 ns	1380	$0.9\text{--}1.7 \times 10^{34}$	40–76
50 ns low emit	1260	$2.2 \times 10^{34}$	108

Requirement after LS1:  $L > 2 \times 10^{34}$ , PU > 50

**Constraint:** Max L1 rate:  $\leq 100$  kHz (< 1kHz logging)

Expect 6x trigger rate (3x – Lu and 2x - energy) increase after LS1 (same thresholds)

Rising trigger thresholds (2x for Single Muon) to retain trigger rate will result in a **detrimental impact on the physics acceptance.**

---

**After LS3:  $L = 5 \times 10^{34}$ , Max L1 rate  $\leq 1$  MHz (10 kHz logging)**



# Strategy

**Improve rate reduction capability  
without affecting efficiency**





# Present CMS Muon System

**DT (MB) < 1.2**

**RPC (RE, RB) < 1.6**

**0.9 < CSC (ME) < 2.4**

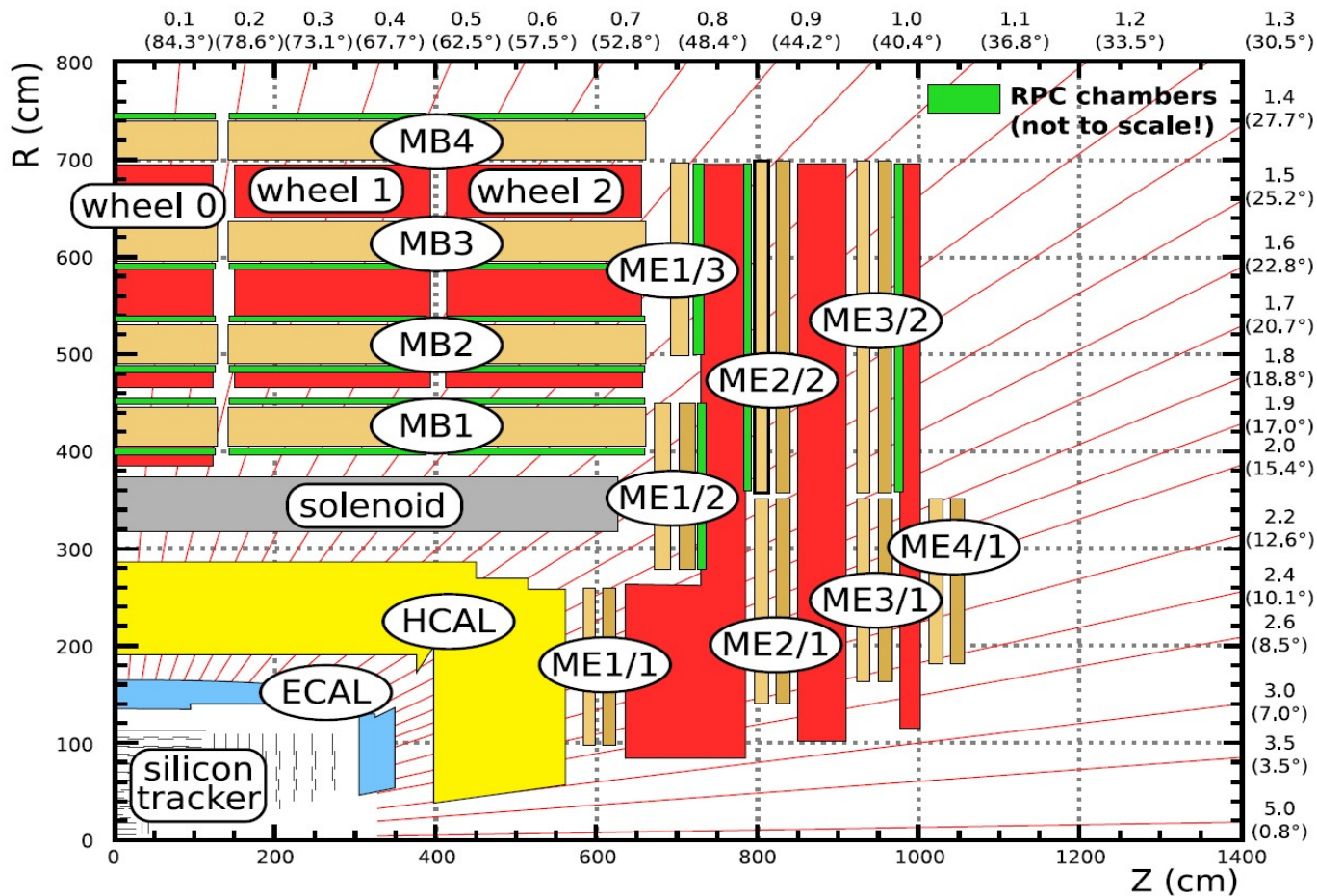

**0.9 < CSC-DT Overlap < 1.25**



# Present Muon Trigger System

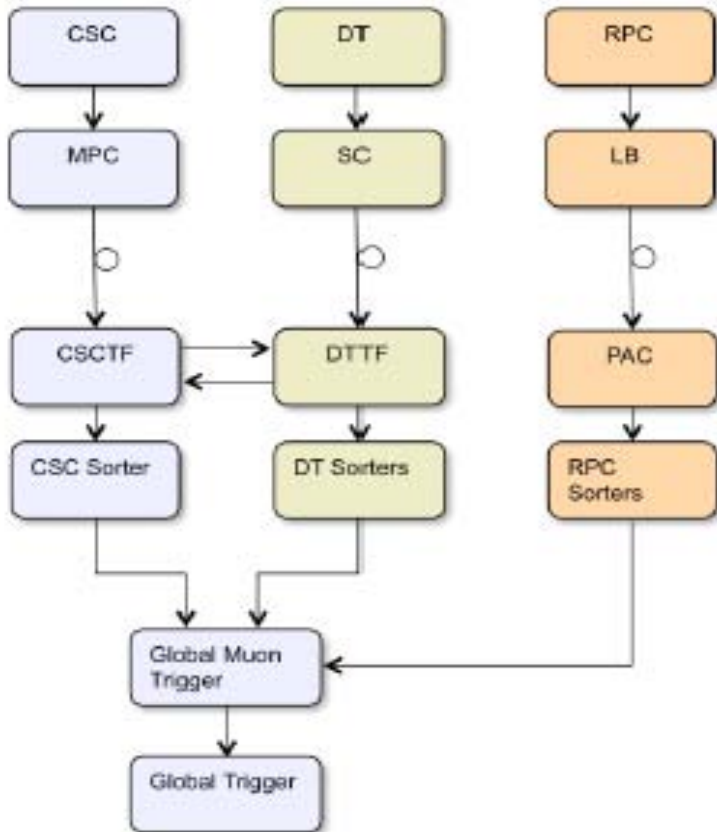

Preserves the complementarity and redundancy of the three separate muon detection systems until they are combined at the GT input

CSCTF  $\Leftarrow$  MPC track segments

DTTF  $\Leftarrow$  SC track segments

PAC  $\Leftarrow$  LB hits

CSCTF  $\Rightarrow$  up to 4 candidates

DTTF  $\Rightarrow$  up to 4 candidates

PAC  $\Rightarrow$  up to 4+4 candidates

Each candidate  $\Leftarrow$   $\{p_T, \varphi(0.05), \eta, Q\}$

GMT merges candidates to eliminate fake muons, assigns  $p_T$

TF – Track-Finder

PAC – PAttern Comparator

MPC – Muon Port Card

SC – Sector Collector

LB – Link Box



# Cathode Strip Chambers

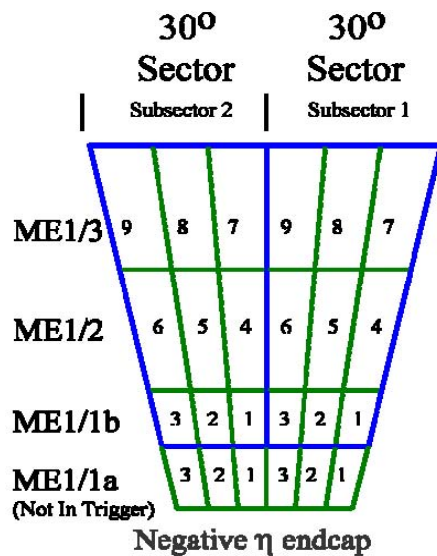
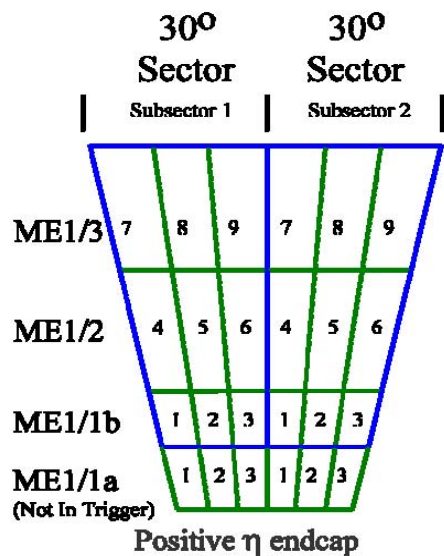

ME1

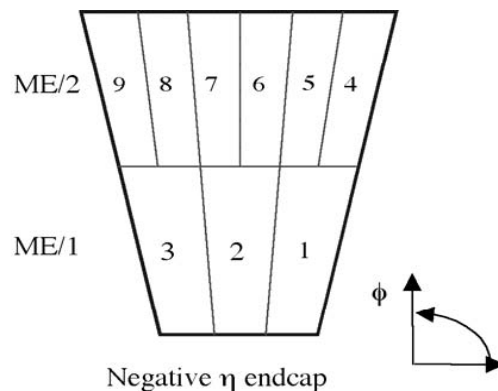
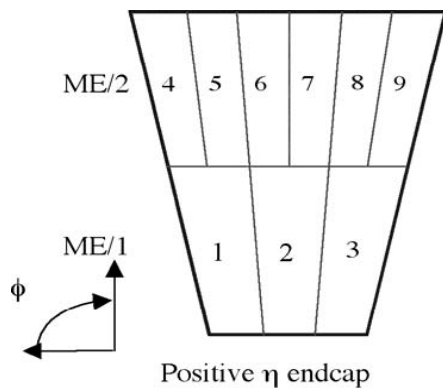

ME2  
ME3  
ME4





# CSC Electronics

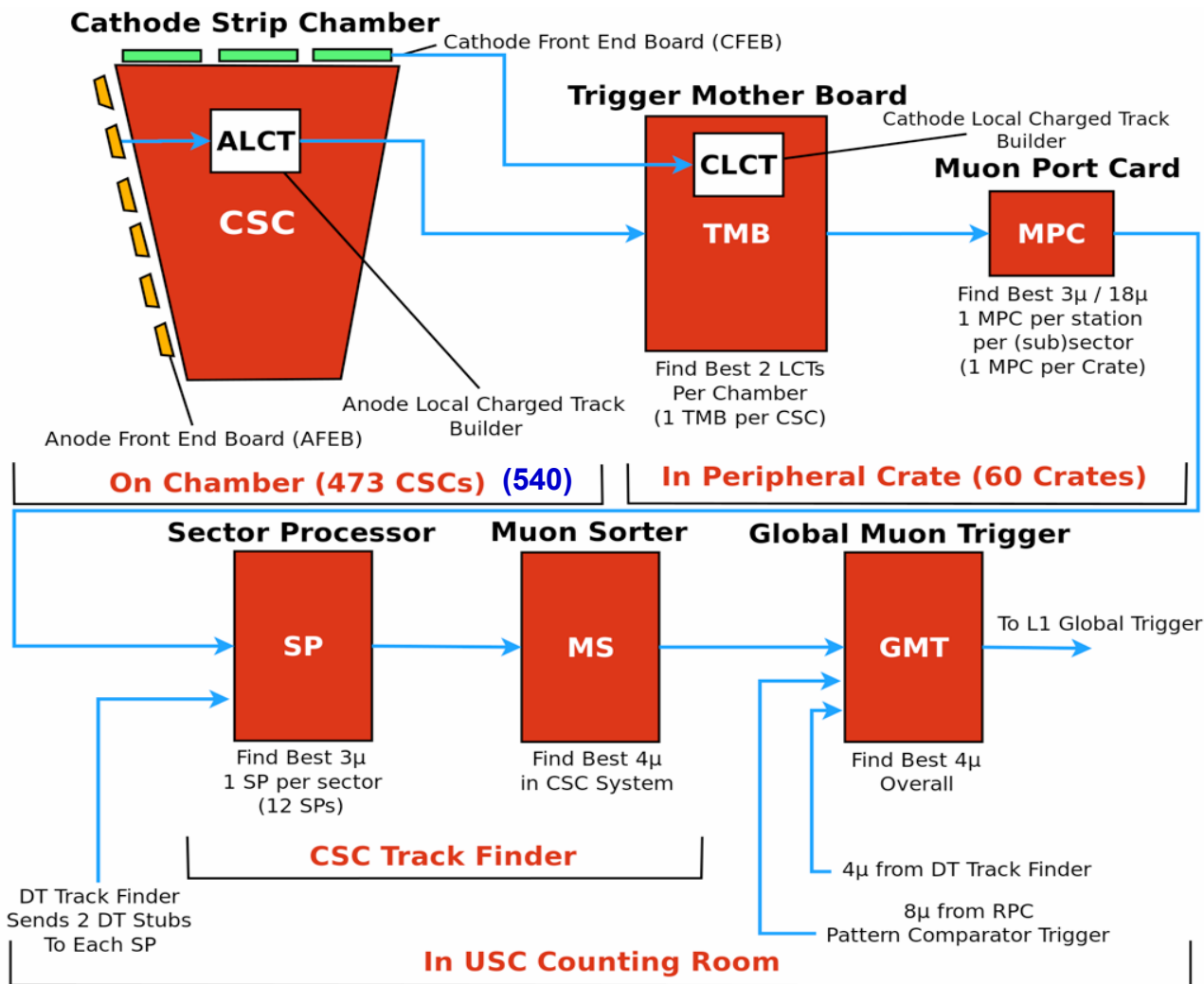



# Present CSC Track-Finder

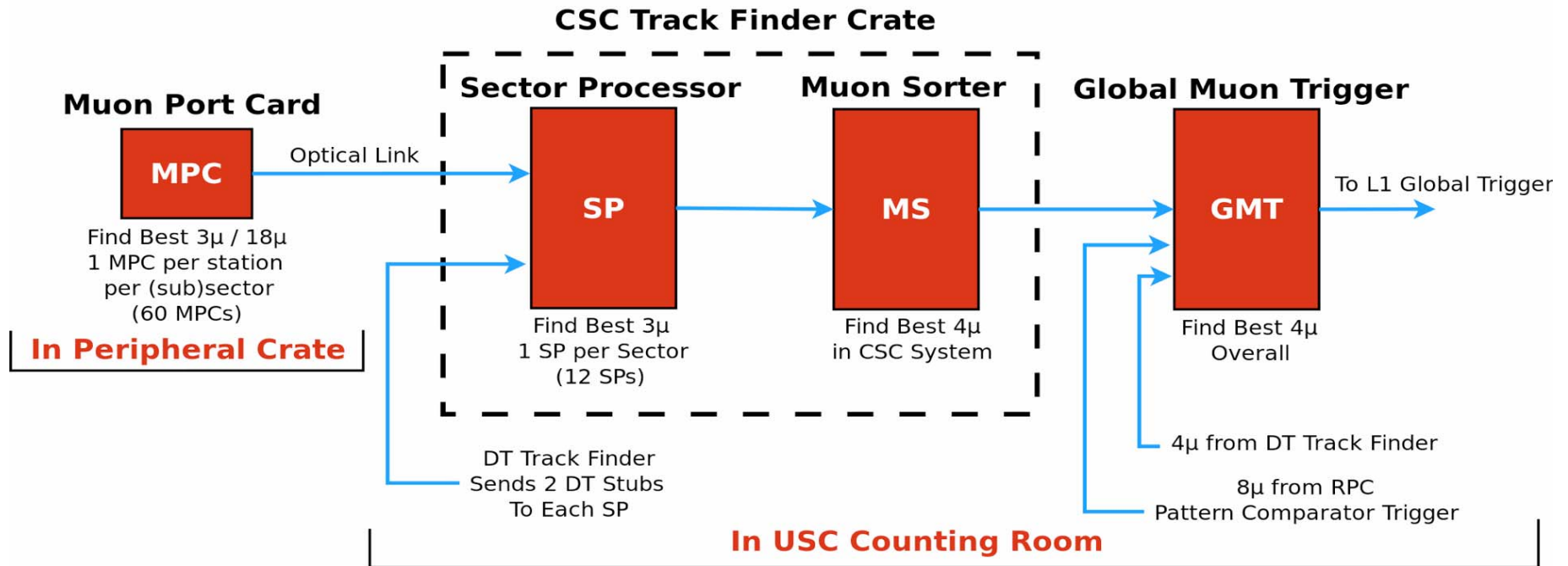





# CSCTF Algorithm

## Track reconstruction in Sector Processor

- 1) conversion of trigger primitives into geometrical parameters  $\{\eta, \varphi\}$  .
- 2) multiple Bunch Crossing Analysis (BXA)  $\Rightarrow$  (+2BX)
- 3) Extrapolation Units (EUs) in  $\eta$  and  $\varphi \Rightarrow$  up to 210
- 4) Track Assembly Units (TAUs) – (12 collision + 6 halo)
- 5) Transverse Momentum (Pt) Assignment Units (PAU) ( $\eta, \varphi, \Delta\varphi$ )
- 6) Final Selection Unit (FSU) (with ghost cancellation)
- 7) Output Multiplexer (OM) (priority of collision over halo)
- 8) BX Correction Unit (BXC) (to second trigger primitive)
- 9) Pt Assignment Lookup Table (Pt LUT)  
( outputs encoded 5-bit Pt and 2-bit track quality (value)



# Drift Tube Chambers

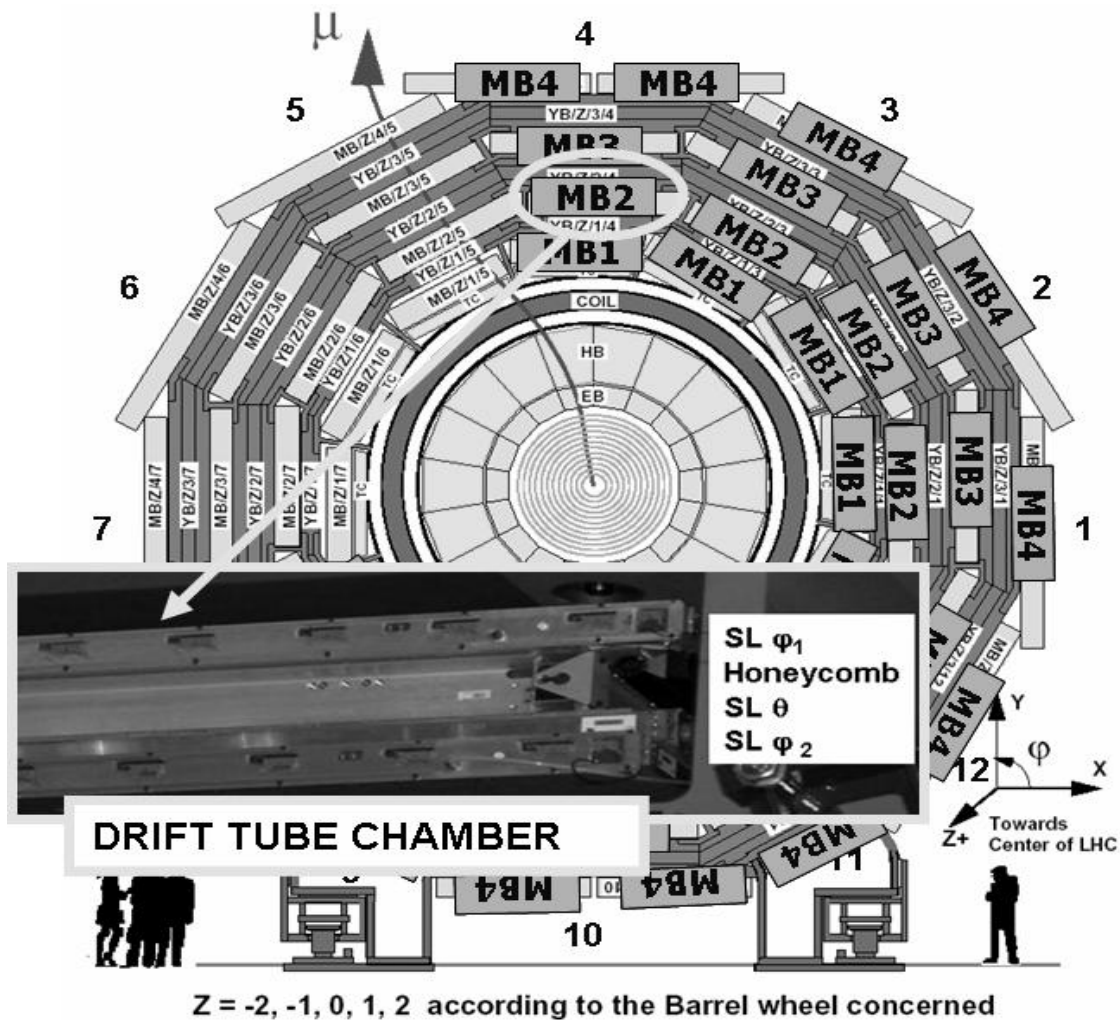



# Present DT Track-Finder

PHTF in  $r$ - $\phi$  plane consists of  
72 SPs in 6 crates

Each SP delivers 2 candidates per BX

72 = 12 wedges ( $30^\circ$ ) x 6 sectors

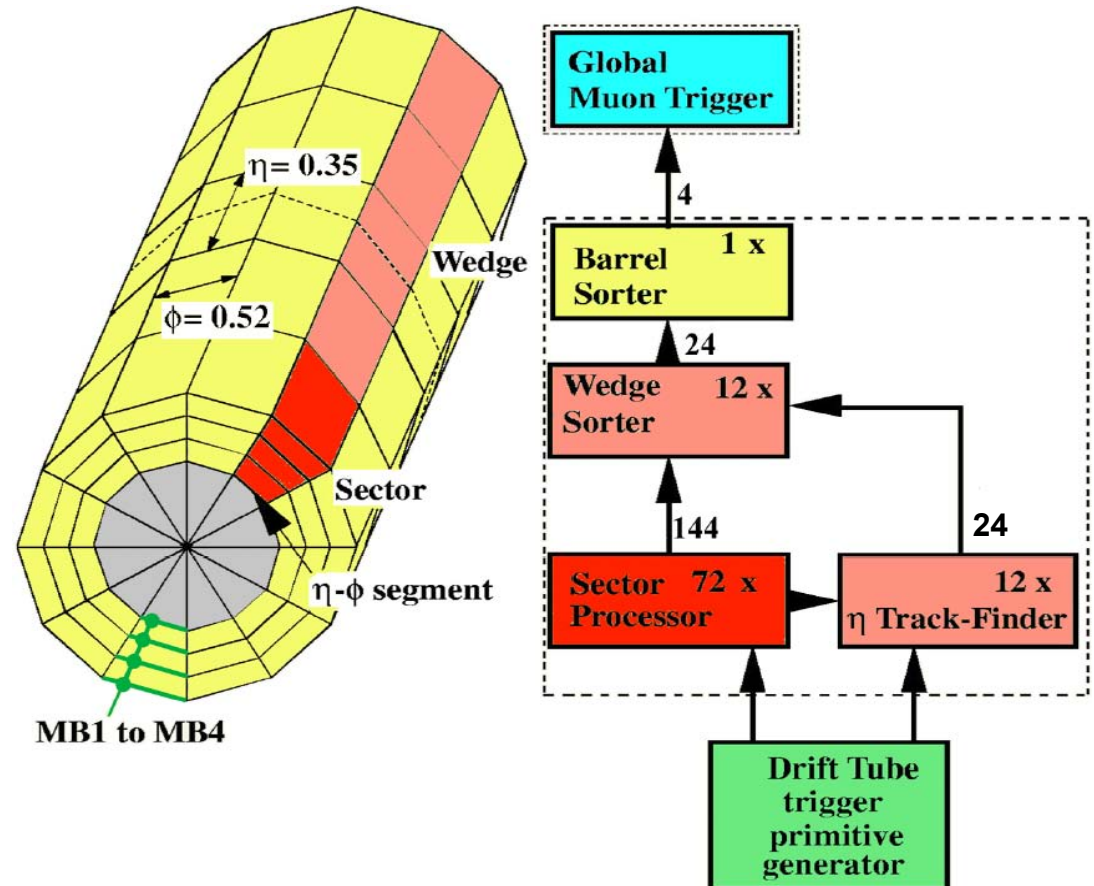

12 ETTF in  $r$ - $z$  plane  
(one per wedge)

MB1-MB3 data only,  
delivers up to 2 candidates per



# Present RPC Trigger

RPC – double gap chambers  
operated in avalanche mode  
RB – 4 stations, 6 layers each  
RE – 4 stations, 3 layers each  
25 towers in eta,  
each subdivided into 144 segments  
in phi

444 Fibers

Pattern matching algorithm  
in 12 trigger crates,  
getting hits from 84 Link Boards to  
84 Trigger Boards (up to 4  
candidates per BX)

PAC has > 2 000 000 patterns  
preloaded

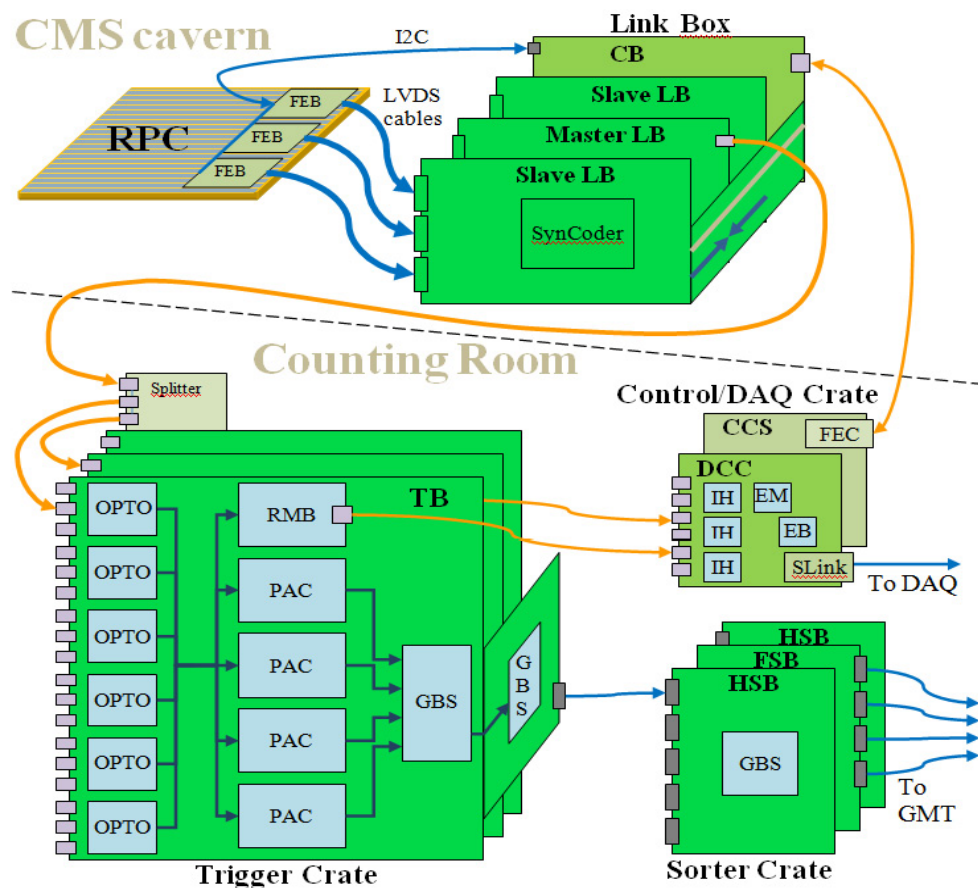



# Areas to Improve

**The Muon Level-1 Trigger is identified as an area which may be improved to meet requirements**

- Muon trigger measures the momentum of muons using the magnetic field in the steel yoke of the CMS solenoid;
- Its resolution degrades with increasing momentum.
- This can be improved
  - by maximizing the number of chamber hits along a muon trajectory
  - by improving the precision and number of position and angular measurements participating in the track fit applied in the trigger logic.
- Isolation criteria can be applied using the energy deposits in the calorimeter in order to further reduce the rate of muons from heavy flavor jets.

**Constraint:  
CMS data-taking must never be put at risk!**

~~Present Muon Trigger:  
Preserves the complementarity and redundancy  
of the three separate muon detection systems  
until they are combined at the GT input~~

Utilize the redundancy of the three muon detection systems **earlier** in the trigger processing chain

Combine muon hits **at the input stage** to the Muon Track-Finder layer rather than at its output

This new **Muon Track-Finder** will ultimately replace the separate track-finders for the Drift-Tube (DT) and Cathode Strip Chamber (CSC) muon triggers as well as the Resistive Plate Chamber (RPC) pattern comparator trigger.



# Feasibility of the Muon Trigger Upgrade

**Great progress in industry since 2000**

**Fiber links => 5x, 10x**

**Serial links => 10 Gb/s**

**FPGA => high speed, capacity, integration with serial links**

**Increase of flexibility**

- ❖ **High bandwidth optical links between trigger cards**
- ❖ **Latest Xilinx FPGAs (series 6, 7) with large logic resources**
- ❖ **Latest Xilinx FPGAs (series 6, 7) with up to 80 GTH Transceivers**
- ❖ **Large memory resources (for tabular calculations - LUTs)**

**Base upgrade on small number of general purpose custom cards (vs current diversity)**

**Same on the software side**

**Implement cards in a telecommunication standard  $\mu$ TCA - 2006 (currently in VME64 – 1994/1997)**

**Commission (whole or slice) in parallel with the current trigger**

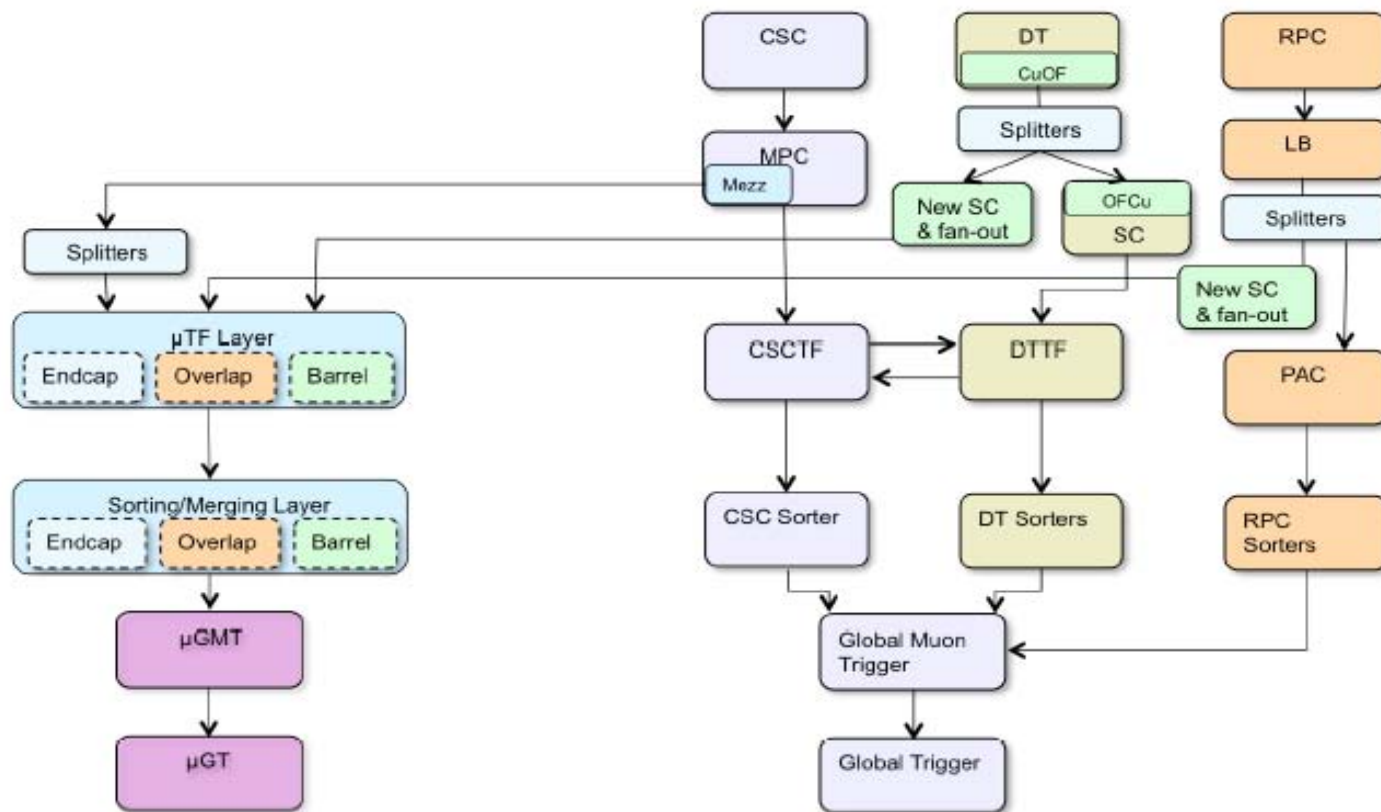

**CMS data-taking must never be put at risk!  
When commissioning updated muon trigger**



# Upgraded Muon Trigger

Isolation criteria can be applied using the energy deposits in the calorimeter in order to further reduce the rate of muons from heavy flavor jets.

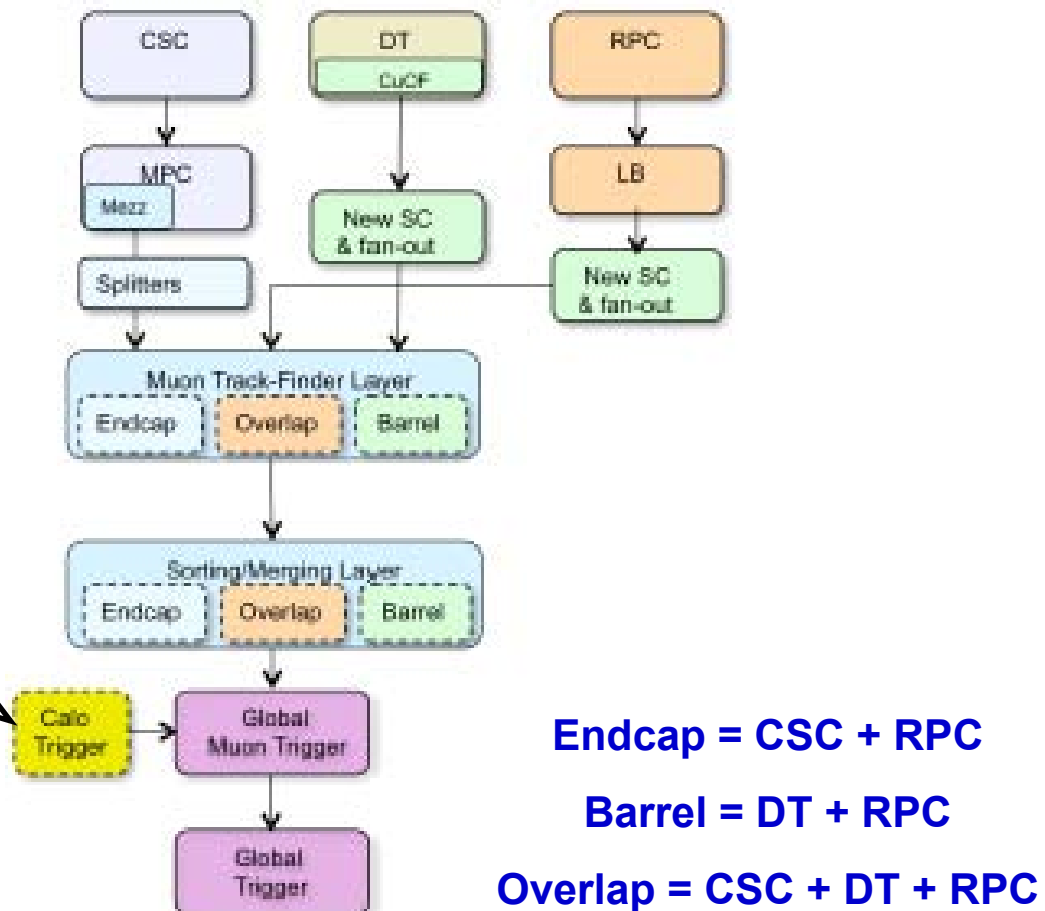



# Compare CMS Muon Systems 2000↔2013

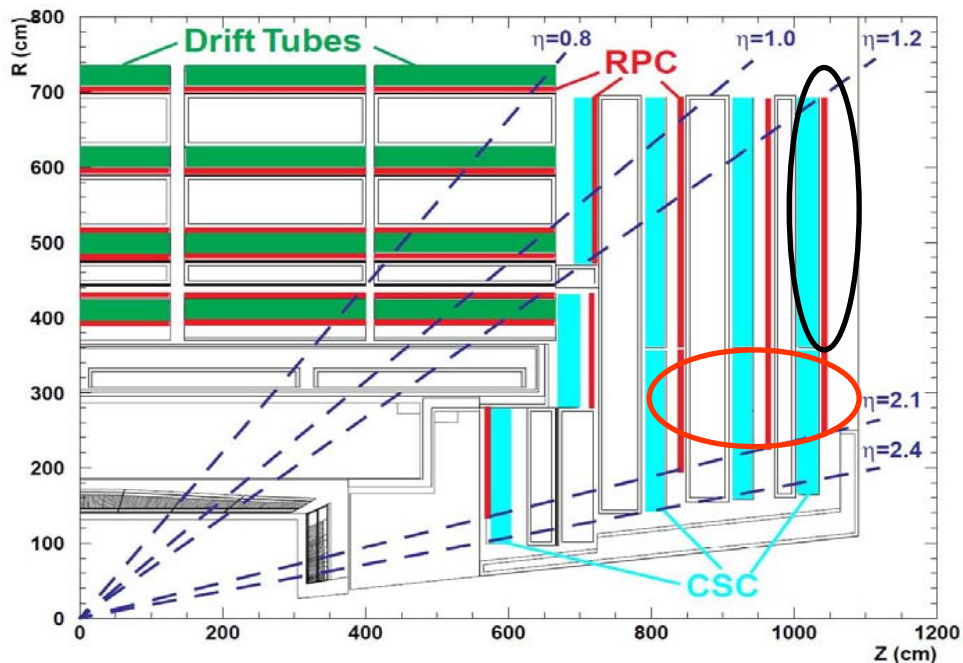

CMS-2000

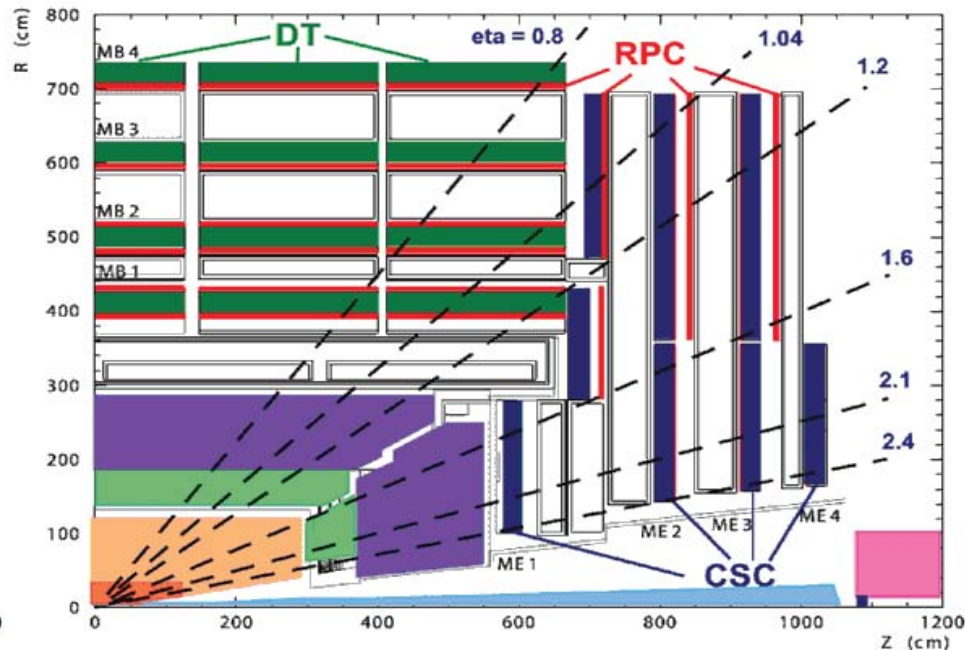

CMS-2013



# CSCTF Issues

**The CSC Sector Processor and Muon Port Card systems will be upgraded to address four issues:**

1. completing the  $\varphi$  coverage of the track finding system,
2. restoring sensitivity to muon jet signatures with no MPC sorting, 2 track segment per chamber (3 => 18),
3. momentum resolution improvement (Larger PT LUT),
4. providing a list of muons to the calorimetry system for isolation calculation and b-jet tagging (MT to CT interconnection)





# CSCTF Issue 1: Coverage in $\phi$

CSCTF Track  $\phi$

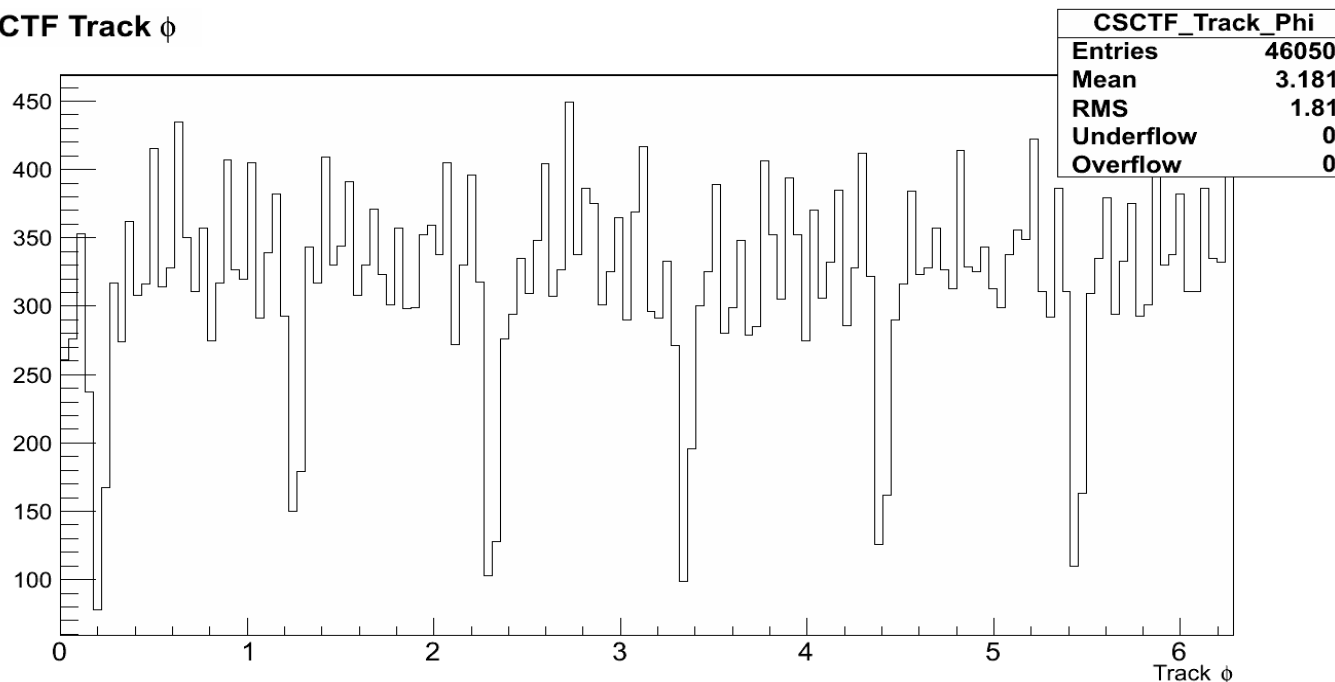

- no cross-talk between sectors in current CSCTF
- muons are lost at the edges of sector phi coverage
- estimate about 5% efficiency loss



# CSC $\phi$ Cross-Talk Scheme

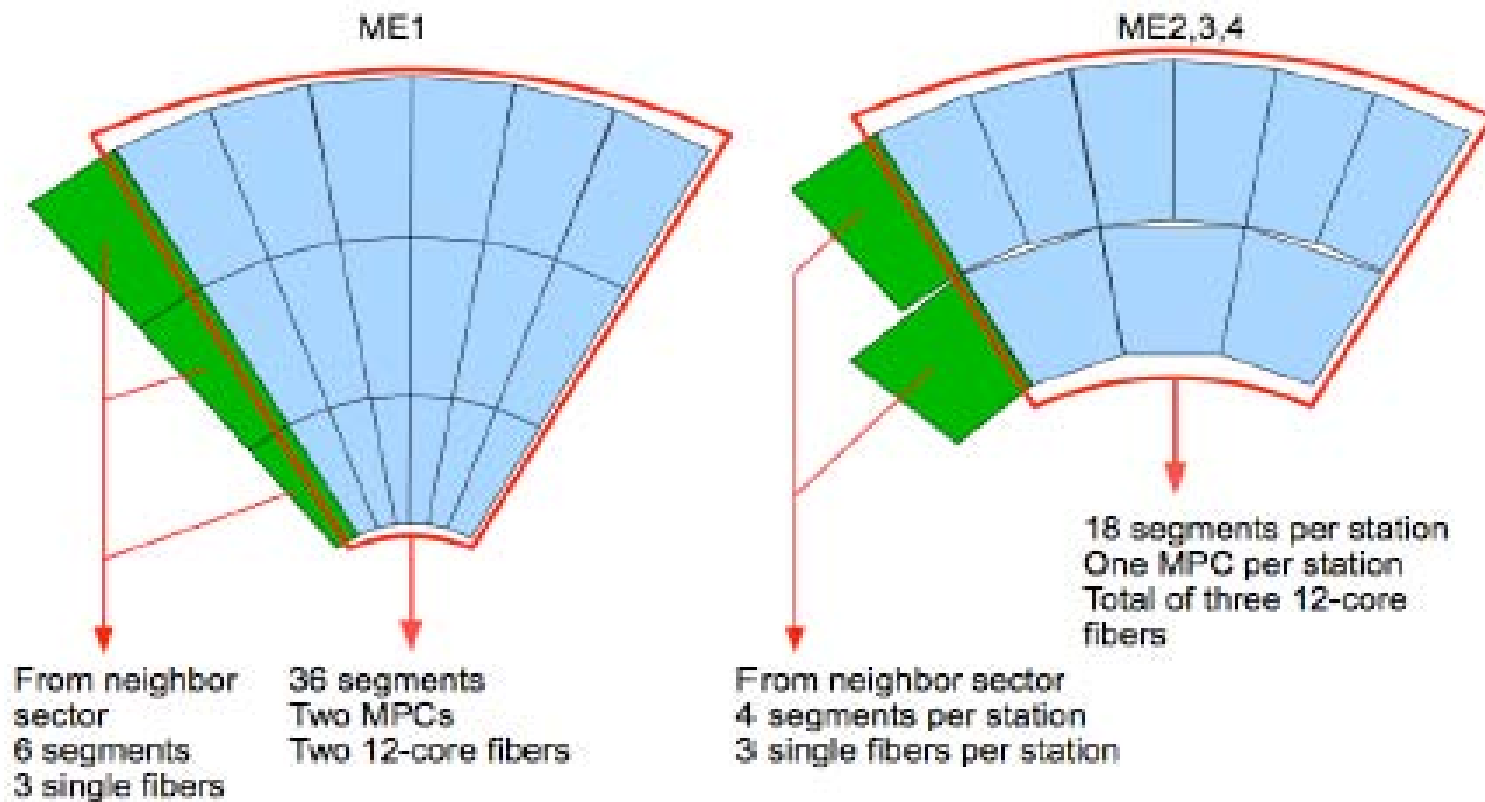



# CSCTF Issue 2: Muon Jets (2 nearby Muons)

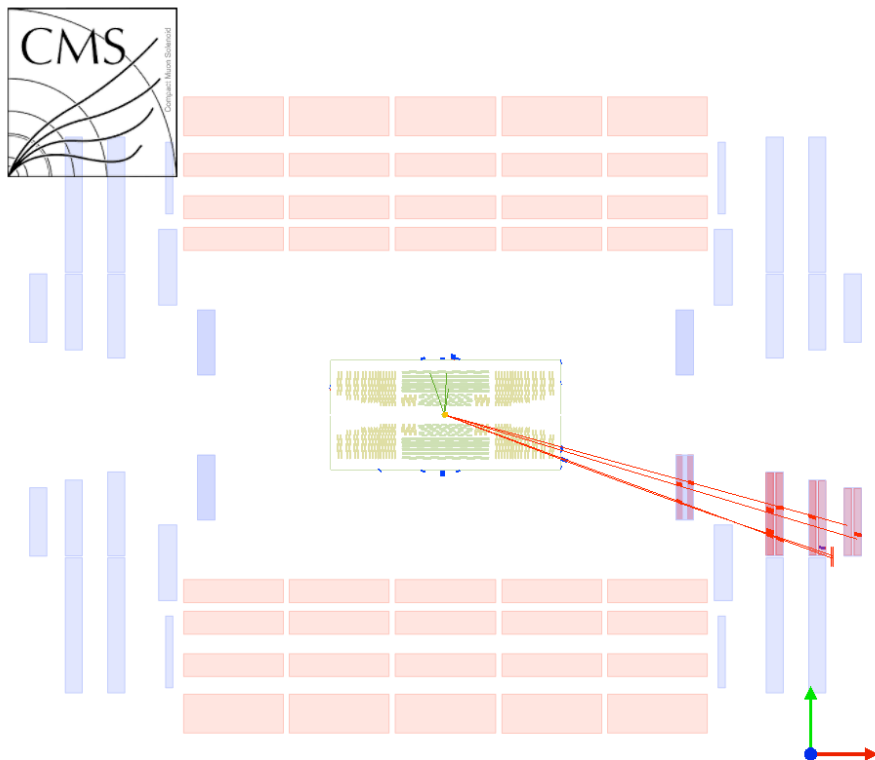

Trigger by requiring 2 nearby muons with  $PT > 10..15$  GeV

If some of the stubs are lost before the Track Finder, TF may not have enough stubs to build a muon track

Efficiency for:	MPC $\leq 3$ stubs	no MPC limit
muon jet of 4 muons	0.83	0.92
muon jet of 8 muons	0.45	0.91



# CSCTF Issue 3: Pt LUT size

Current – pT assignment information

Upgrade – full information available at SP

$\phi \Rightarrow (0.05 \text{ vs } 0.015)$       LUT: 2M x 16  $\Rightarrow$  1G x 18

The larger LUTs the better rate reduction

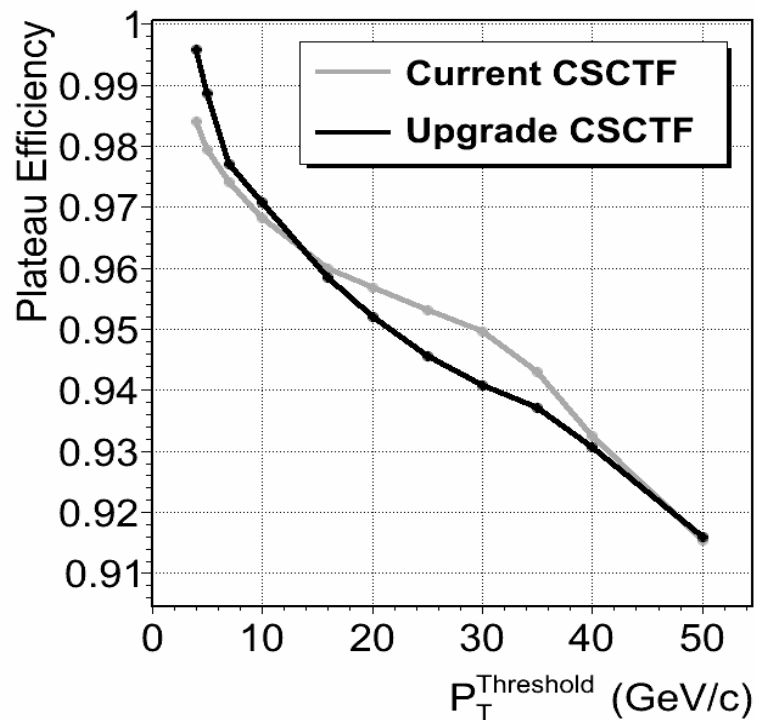
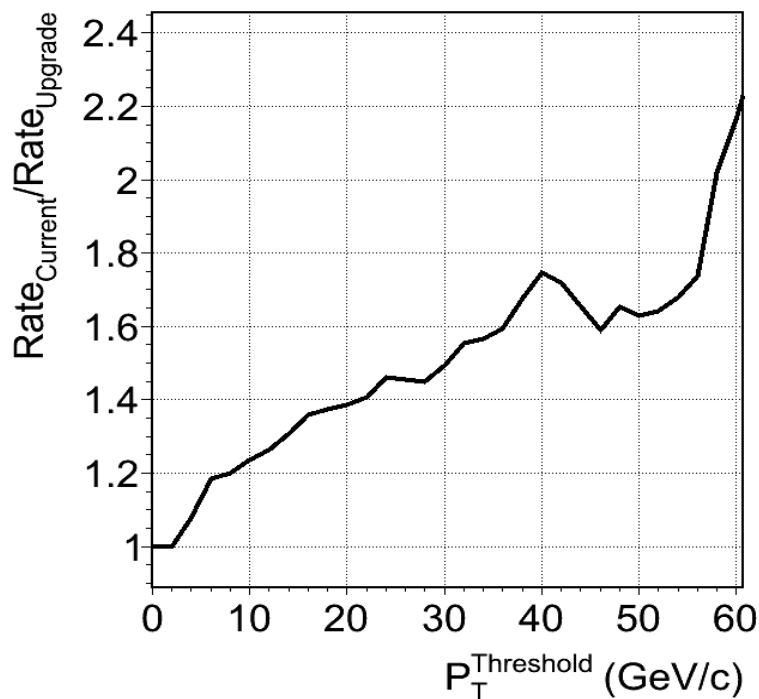

1. TSCs are located in aggressive environment => relocate to USC,
2. Flat cable connection are unreliable (green salad) => go to serial

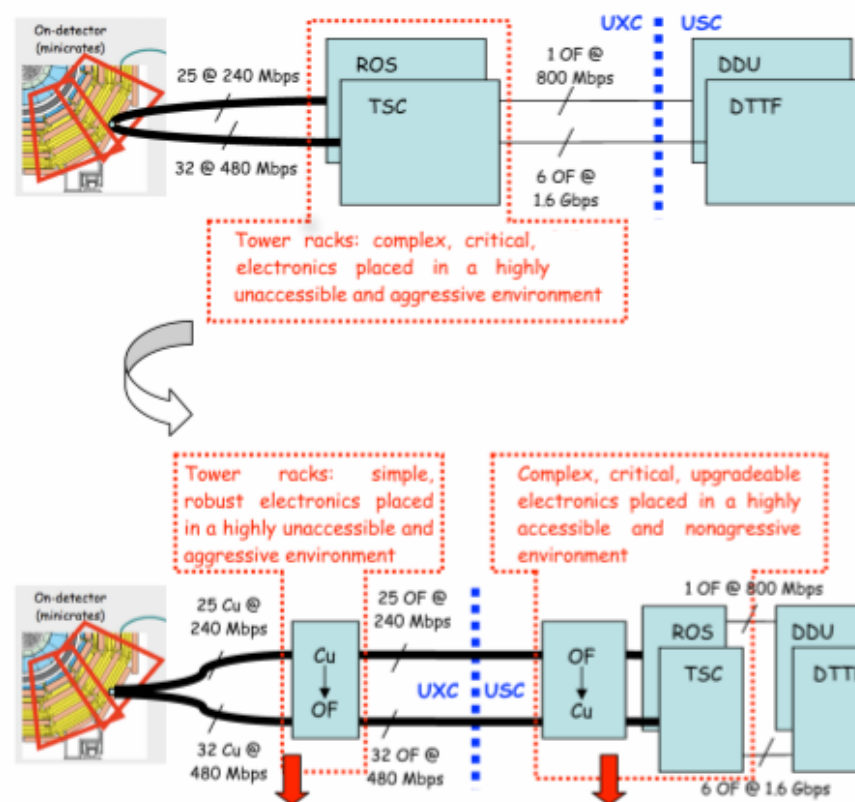



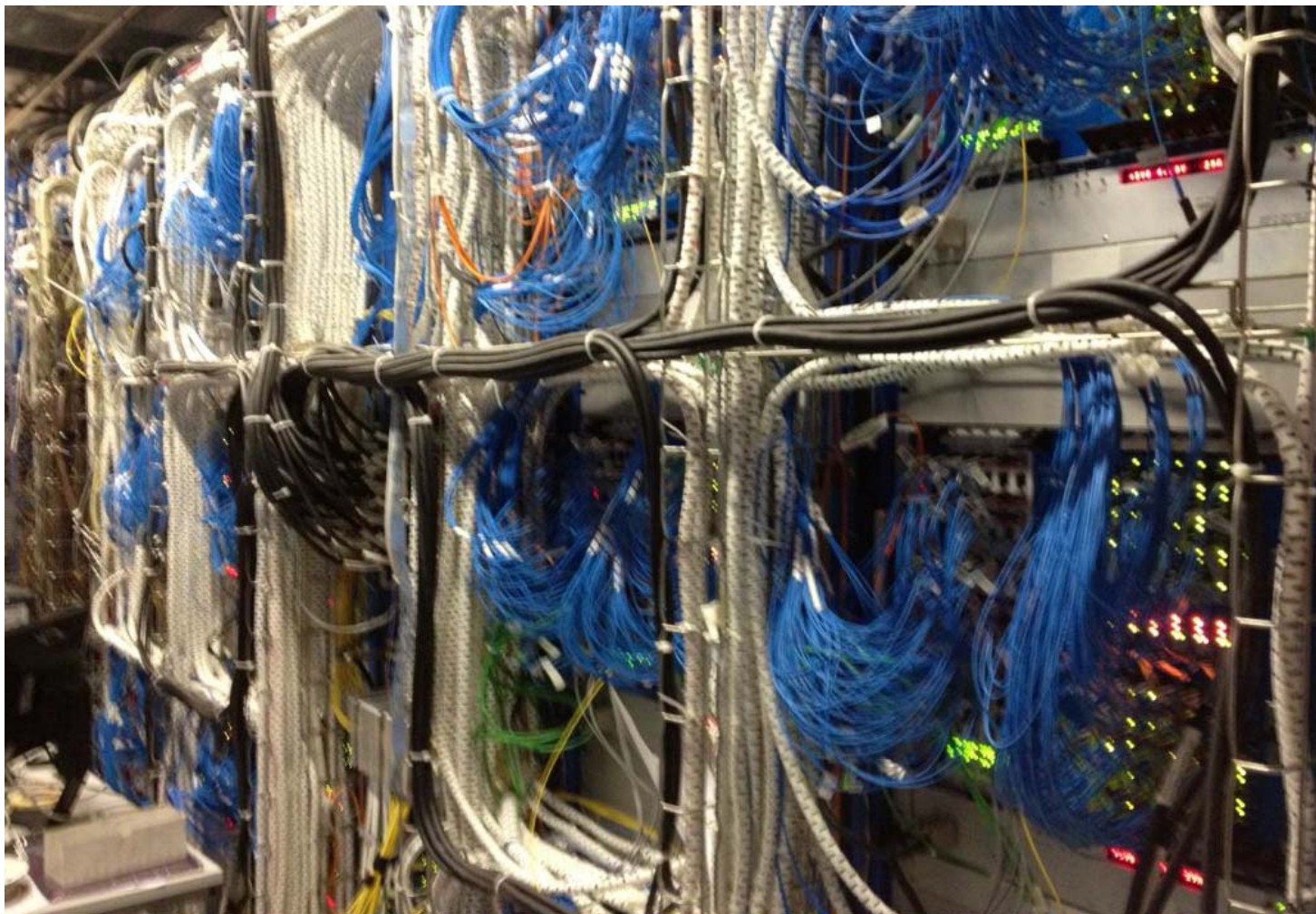



# CSCTF (MTF7) Prototype

Custom backplane section  
Serial lines between  
two modules only

Connection to  
VT892 standard  
backplane

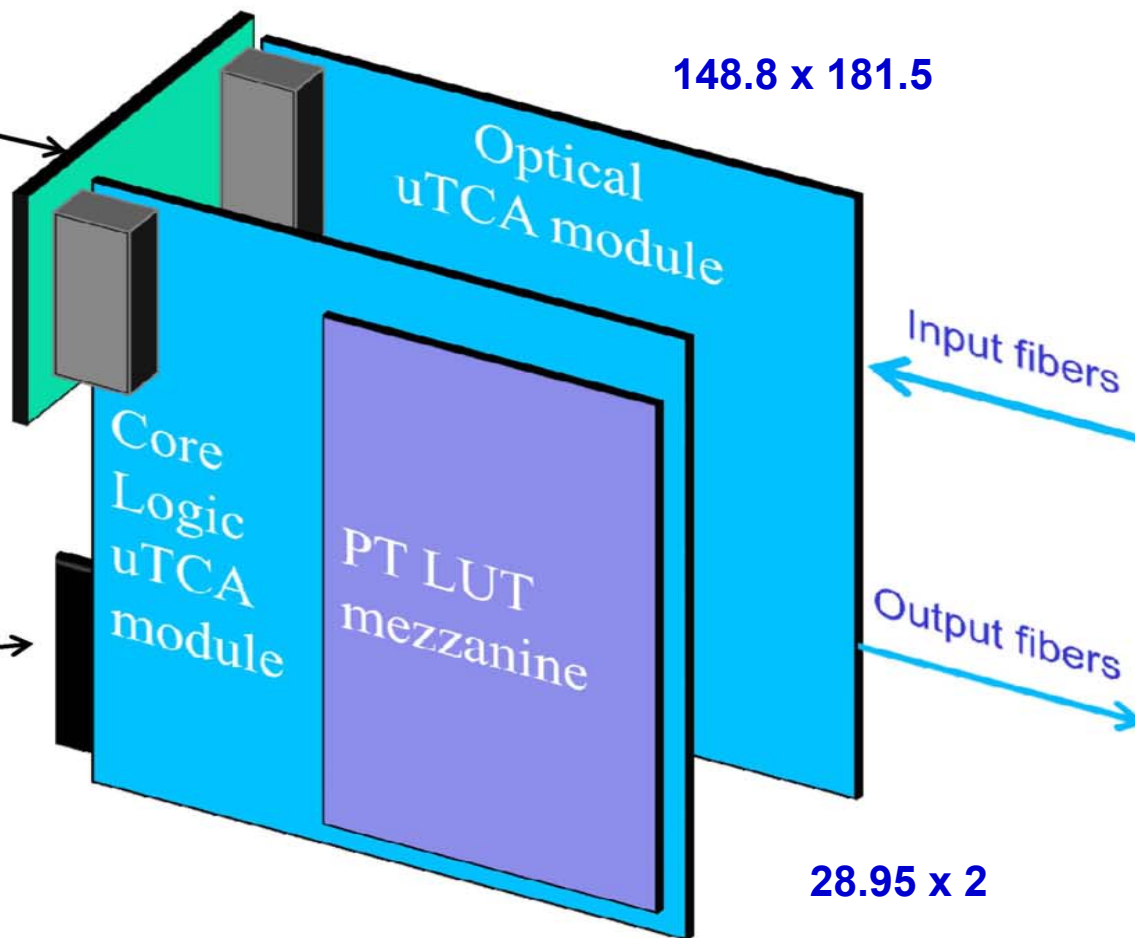



# CSCTF (MTF7) Prototype

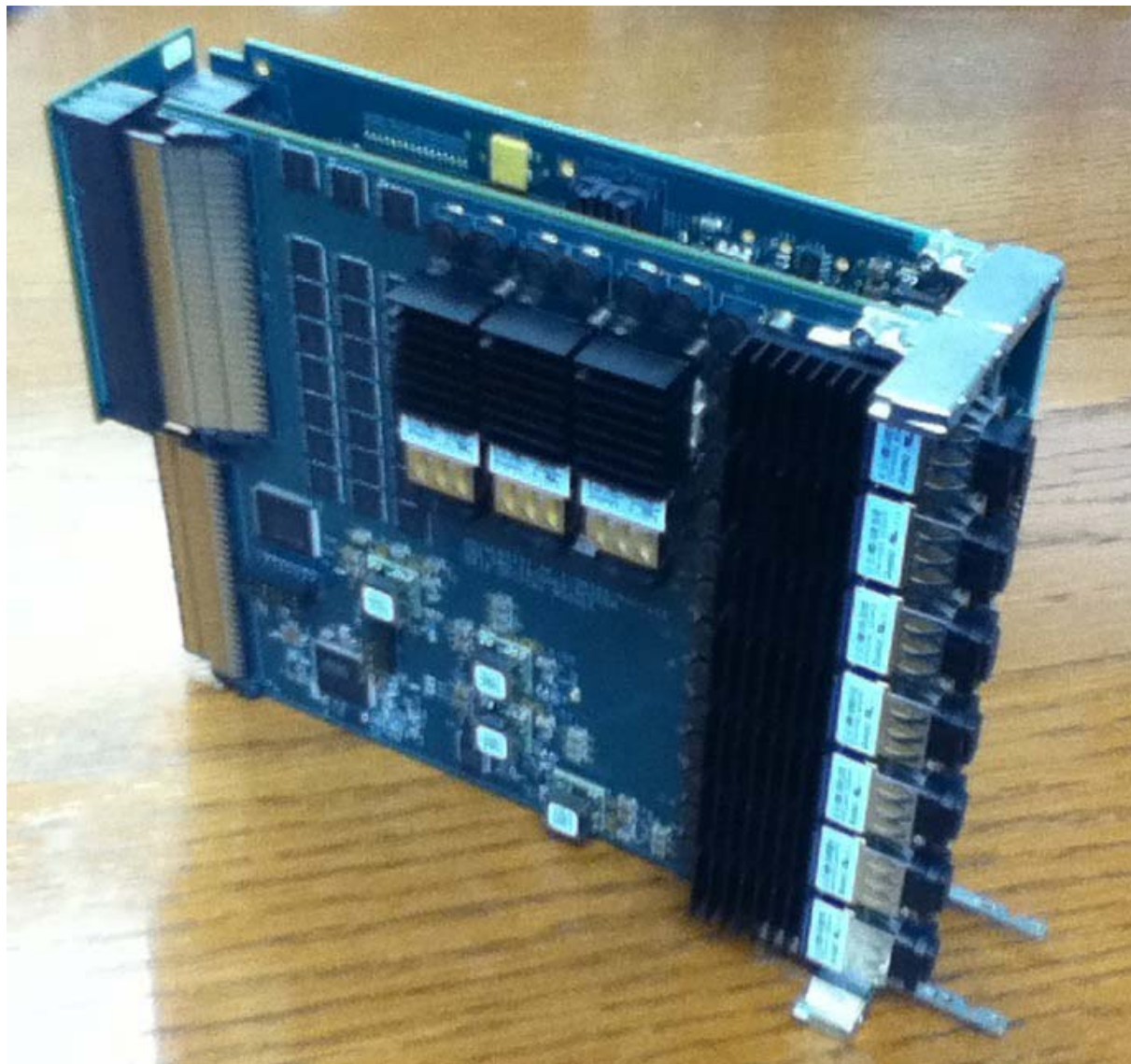



# Optical AMC Prototype

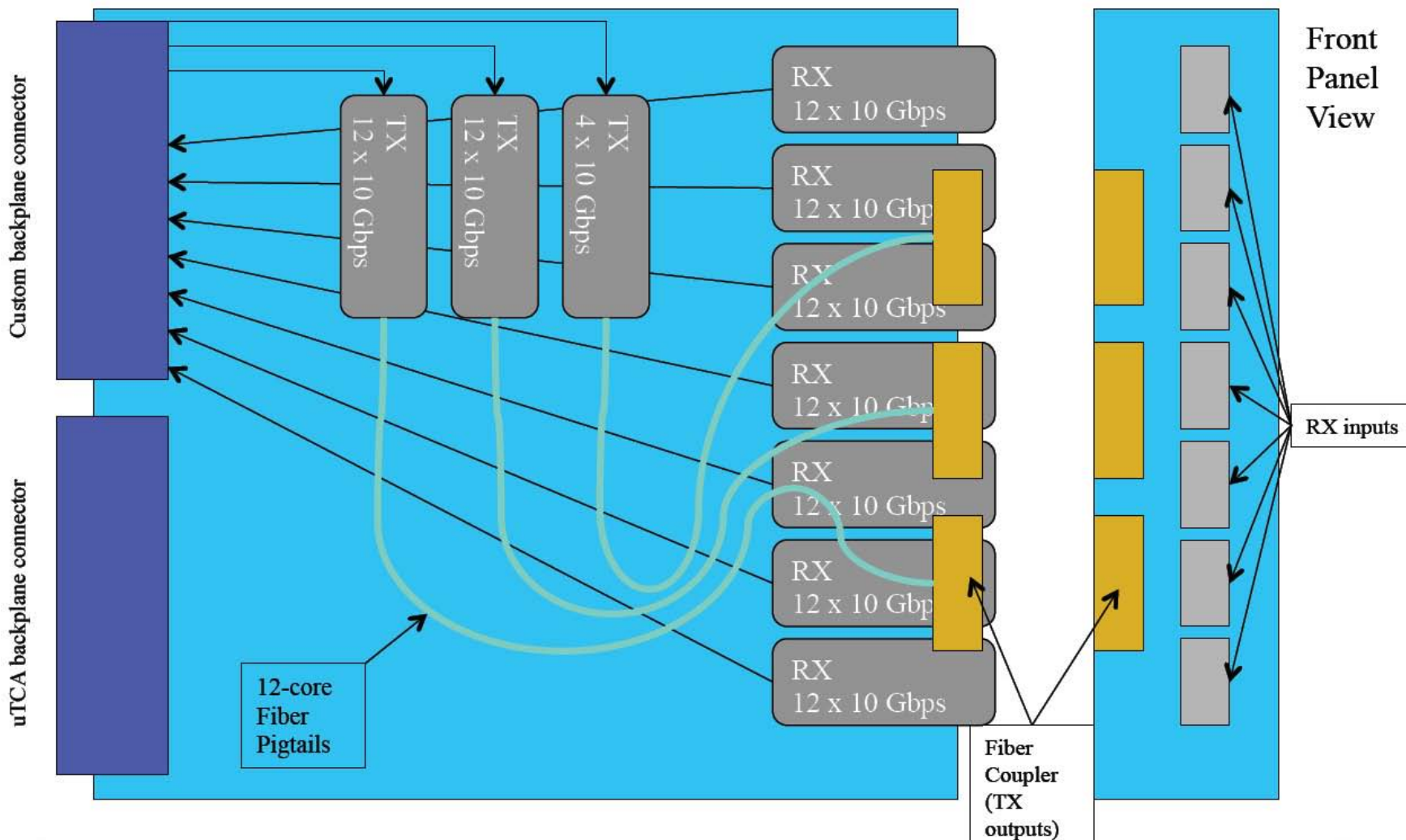

# Optical AMC Prototype

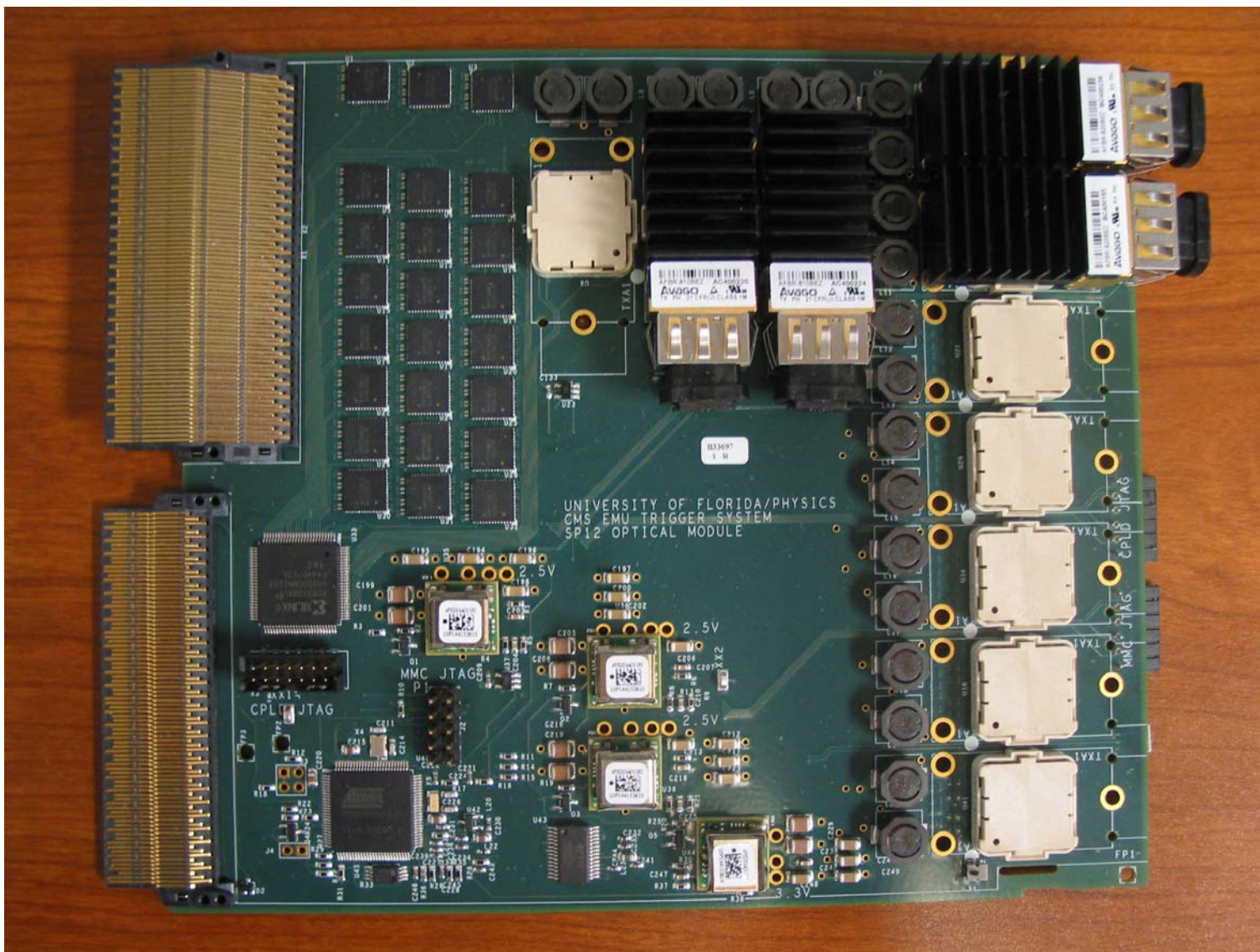

# Core AMC Prototype

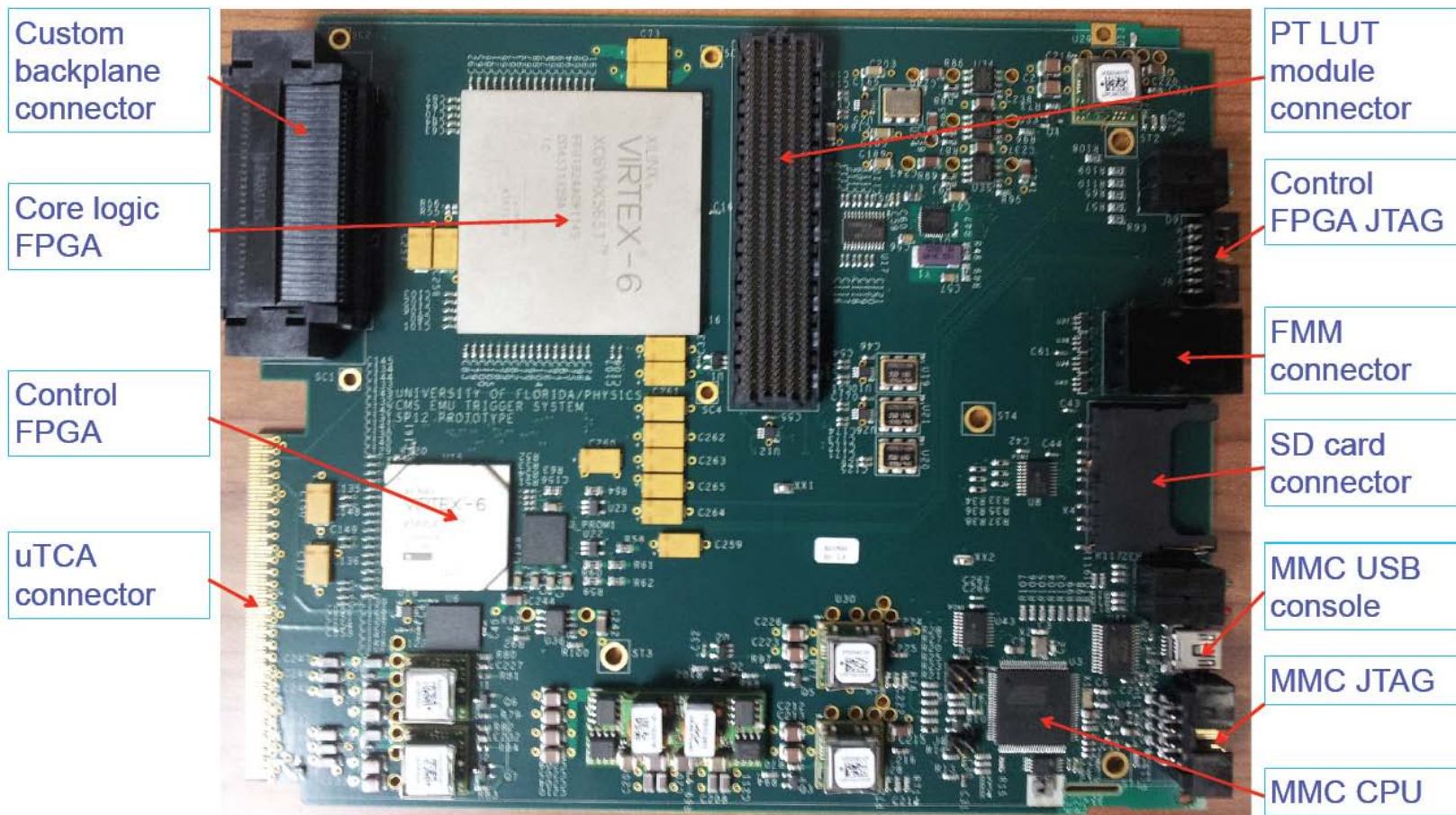

Estimated power consumption: ~40 W (assuming FPGAs nearly full)  
 PT LUT mezzanine not included



# CSCTF $\mu$ TCA Layout

Chassis #1



Chassis #2

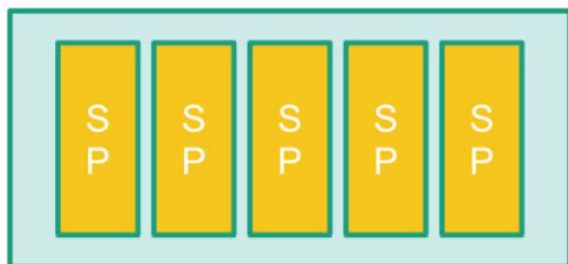

Chassis #3



Possible layout of the endcap muon track-finding processors and corresponding muon sorter into three  $\mu$ TCA crates.

All hardware modules are identical and occupy 2 slots.

The MCH and AMC13 in each crate are not shown.



- **Develop more sophisticated algorithms for MTF**
- **Possibly switch from extrapolation to pattern matching (à la RPC PAC)**
  - ➔ **Extrapolation not well scalable with increasing number of input track segments (6x !)**
- **Negotiate and set up interfaces between muon systems**
  - ➔ **Ideally all muon systems (CSC, DT, RPC) should provide track segments in compatible formats**
- **Agree upon interface between TF layers and Sorting and Merging Layer**
- **.....**

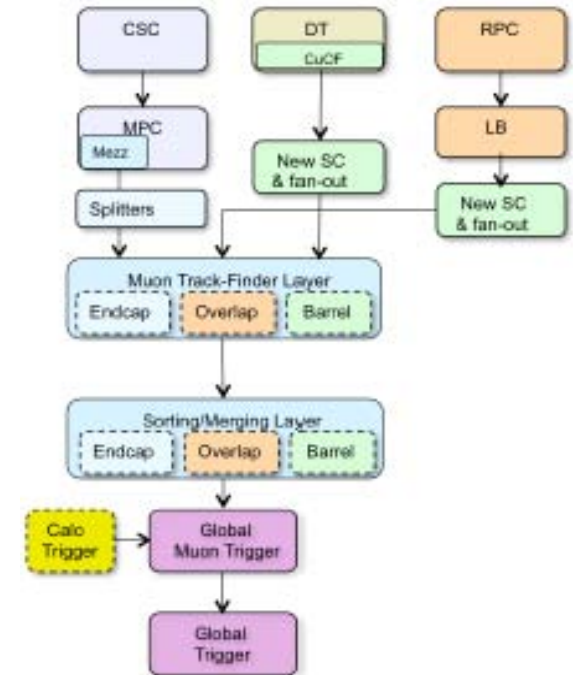





# Participating Institutions

## Institution

HEPHY Vienna (AT)

University of Athens (GR)

University of Ioannina (GR)

INFN Padova (IT)

University of Warsaw (PL)

National Centre for Nuclear Research, Warsaw (PL)

Warsaw University of Technology (PL)

CERN (Switzerland)

Ohio State University (USA)

Rice University (USA)

University of California, San Diego (USA)

University of Florida (USA)

PNPI (Russia)

## Areas of interest

Global Trigger and Muon Trigger

Muon Trigger

Muon Trigger

Muon Trigger

Muon Trigger

Muon Trigger

Muon Trigger

Trigger Control and Distribution System

Global Trigger

Muon Trigger

Muon Trigger

Muon Trigger

Muon Trigger ???????



# CSCTF Cost Estimates

Date	Module/component	Stage	Cost
2012-09	Core logic module	prototype	\$29,130
2012-11	Optical module + backplane	prototype	\$19,250
2013-03	PT LUT module	prototype	\$16,800
2013-10	All modules	pre-prod	\$63,630
2014-05	All modules	production	\$317,760
2014-09	uTCA chassis, optical parts	COTS	\$102,136
<b>Total</b>			<b>\$548,706</b>



# L1 Trigger Upgrade Costs

<b>Area</b>	<b>Total cost (kCHF)</b>
<b>Calorimeter Trigger</b>	<b>2,527</b>
<b>Endcap Muon Track Finder</b>	<b>963</b>
<b>Barrel Muon Track Finder</b>	<b>883</b>
<b>Overlap Muon Track Finder</b>	<b>593</b>
<b>Global Trigger and GMT</b>	<b>628</b>
<b>Total cost</b>	<b>5,593</b>



# Back up slides







# Pattern Matching Algorithm

- Phi pattern detection is in double strips, to save logic
  - ▣ Detection precision seems to be sufficient
  - ▣ Full 12-bit phi will be assigned to the best tracks
- Phi patterns are constructed so that:
  - ▣ They accommodate max 10 degree bending (ME1-ME2)
  - ▣ High-PT (straightest) tracks are detected most precisely
  - ▣ As bending increases, the precision becomes worse
  - ▣ Minimum two layers must be hit
- Quality code:
  - ▣ The more layers – the better
  - ▣ Patterns with ME1 hit have priority
- Theta patterns are similar but simpler
  - ▣ No bending in theta direction

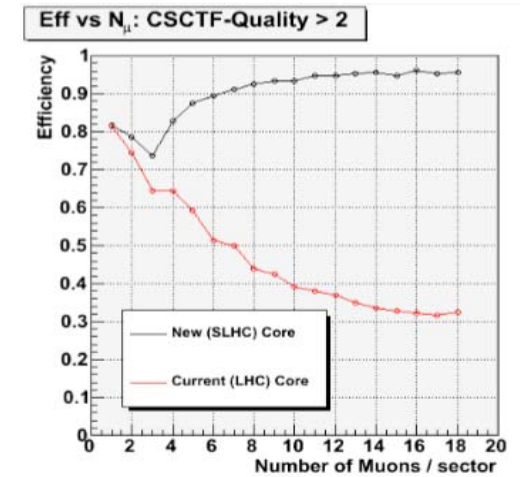
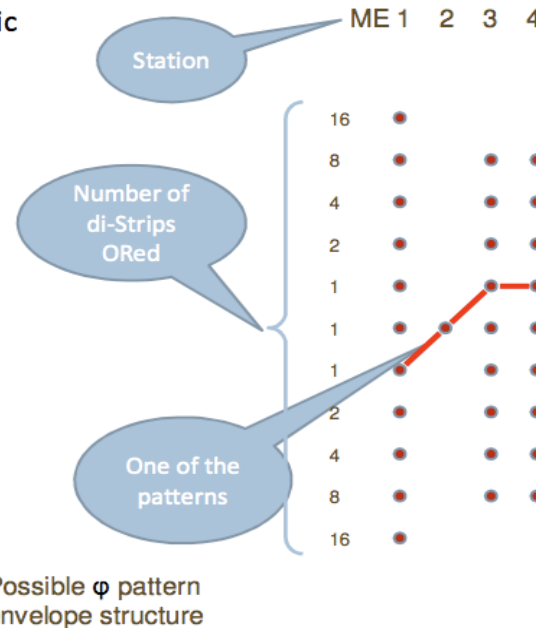

## SP upgrade - track finding

- current design -  $\phi$  comparisons, does not scale well
- switch to pattern matching system for upgrade



Schedule Estimation	Project Stage	Project Materials	Project Labor
05.2013 12.2013	Prototype Development	$\mu$ TCA Crate assembled AMC13 module, Core and Optical modules, MPC Port Card Prototype	Track Finder Prototype Simulation and Test Software Interface Prototype Development Firmware Prototype Development
01.2014 09.2014	Track Finder Production and Testing	Track Finder Modules and Firmware	Track Finder Modules Debugging and Testing

Schedule Estimation	Project Stage	PNPI Project Manpower	Cost Estimation
05.2013 - 12.2013	Prototype Development	4 Electronics Engineers 2 Software Engineer	200 KCHF
01.2014 - 09.2014	Track Finder Production and Testing	4 Electronics Engineers 2 Software Engineer	393 KCHF